

**AC SOURCE**

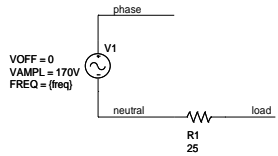

**DIMMER**

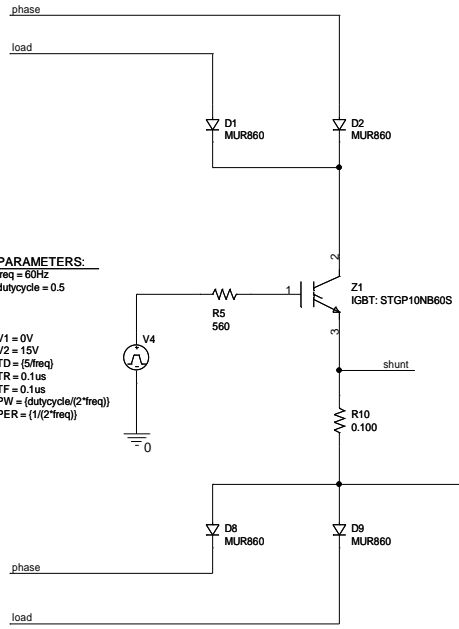

**POWER SUPPLY**

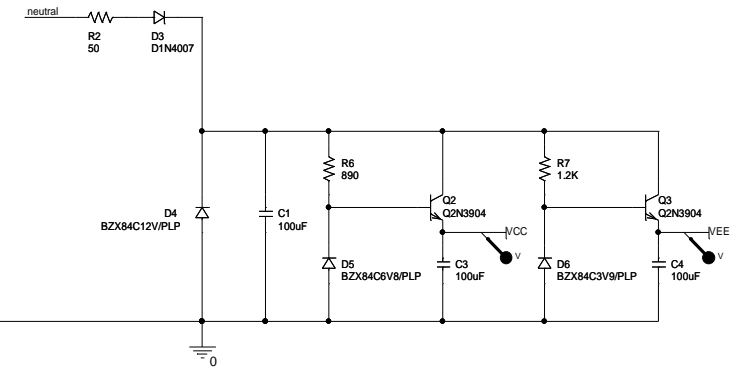

**CURRENT SENSOR**

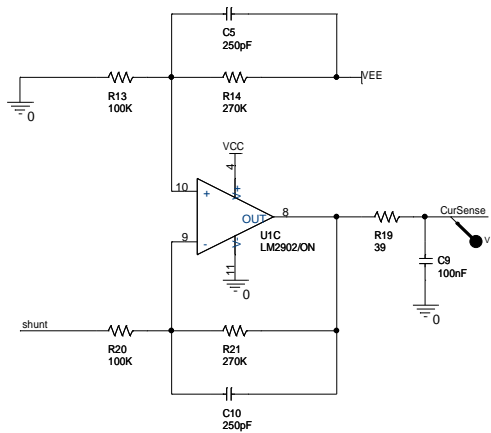

**VOLTAGE SENSOR**

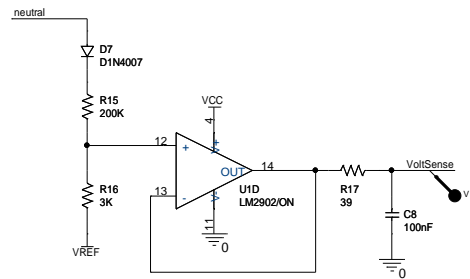

**VOLTAGE REFERENCE**

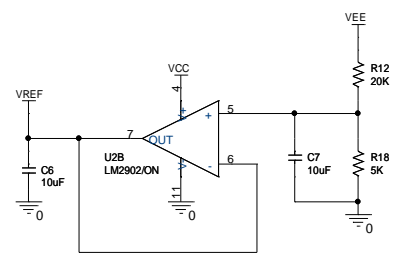

**ZERO CROSSING DETECTOR**

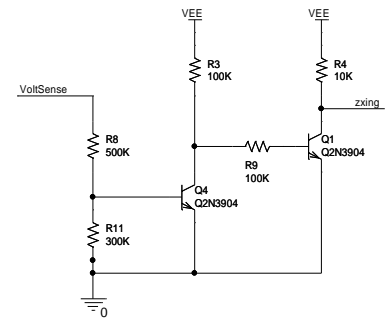

Title		
Dimmer: IGBT, Inside Power Supply		
Size	Document Number	Rev
A3	112	A
Date:	Monday, June 07, 2010	Sheet 1 of 1